



Electric reach truck

ETV 114n / 116n / 118n / 120n

Lift height: 1800-5300 mm / Capacity: 1400-2000 kg

Space-saving design, excellent performance and comfortable working area-these are the strengths of the Jungheinrich Reach Trucks ETVn 1 series. The advantages:

Space-saving through narrow working aisle widths from 2659 mm (according to VDI-when picking up a pallet length-ways).

Higher throughput as well as increased availability due to 3-phase AC technology drive, lift and steering motors.

Motivated and stress-free operators due to efficiency enhancing ergonomics. The operator is immediately aware of the added comfort: Using the lowered step, he comfortably gets into the operator compartment equipped with 3-fold adjustable seat as well as a steering wheel adjustable in horizontal and vertical directions. Automatic speed reduction in corners. curveCONTROL limits maximum travel speed and acceleration in corners. The danger of tipping over is drastically reduced.

ETV 114n / 116n / 118n / 120n

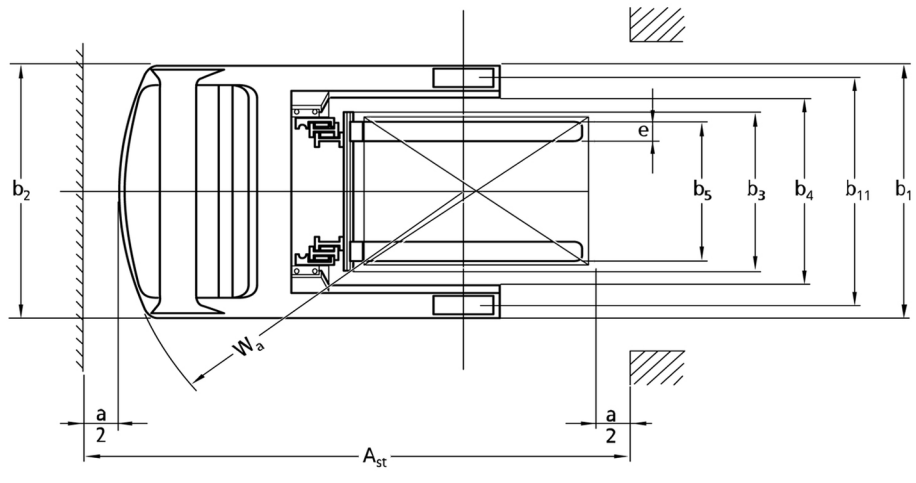
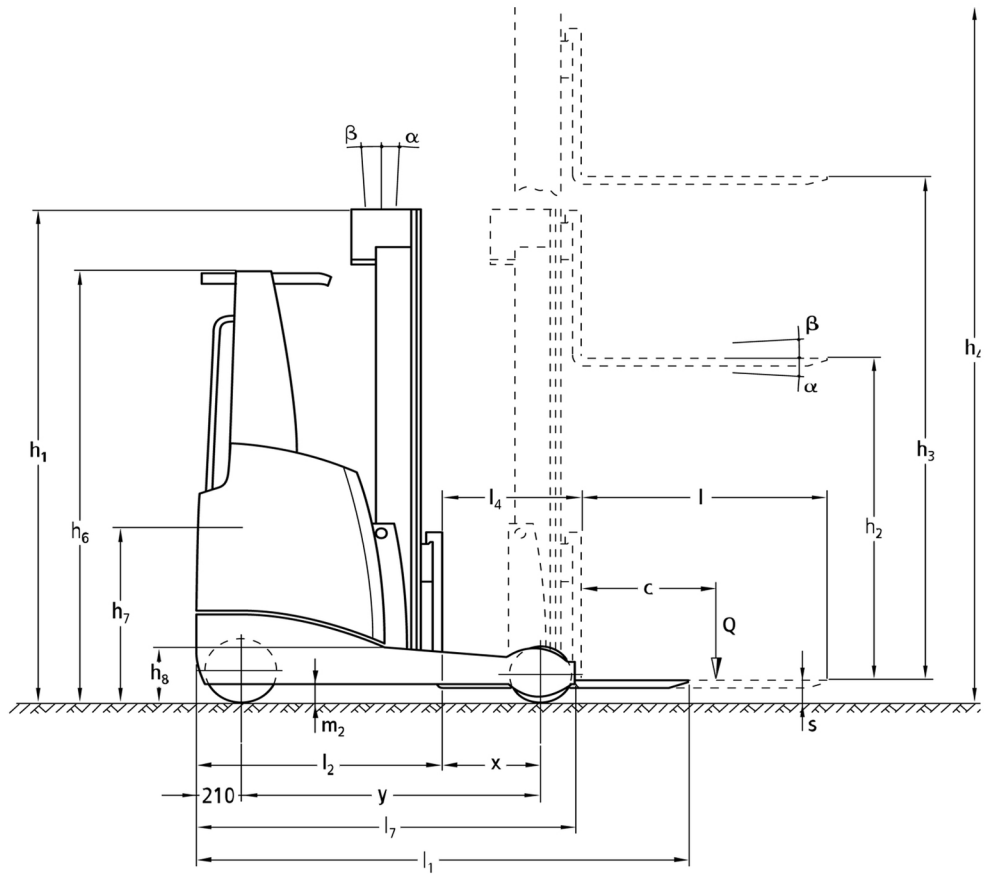

ETV 114n / 116n / 118n / 120n

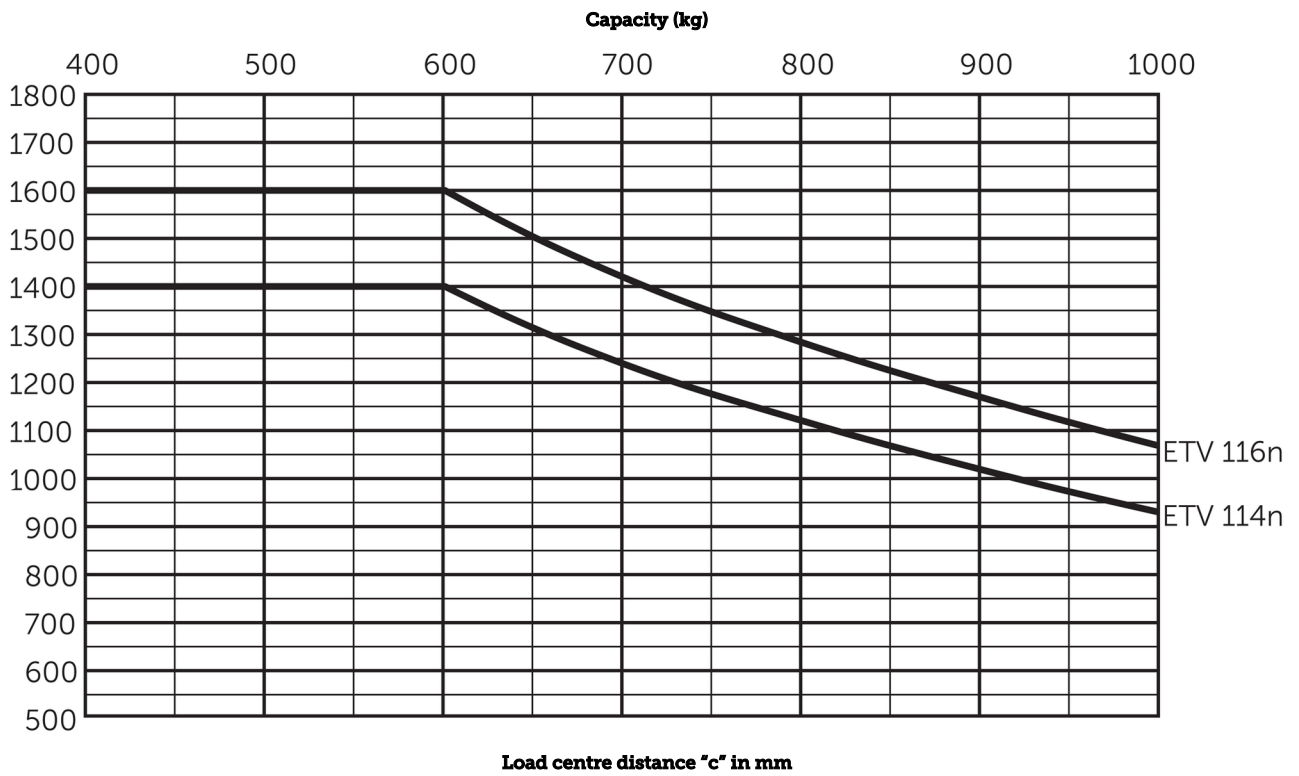

ETV 114n / 116n / 118n / 120n

ETV 114n, ETV 116n	Lift (h3)	Retracted mast height (h1)	Free lift (h2)	Extended mast height (h4)	Tilt of mast forwards/backwards	Tilt of fork carriage forwards/backwards
Triplex mast DZ	5000 mm	2200 mm	1700 mm	5590 mm	1 / 5 °	
	5000 mm	2200 mm	1700 mm	5590 mm		2 ° / 5 °
	5300 mm	2300 mm	1800 mm	5890 mm	1 / 5 °	
	5300 mm	2300 mm	1800 mm	5890 mm		2 ° / 5 °
	5900 mm	2500 mm	2000 mm	6490 mm	1 / 3 °	
	5900 mm	2500 mm	2000 mm	6490 mm		2 ° / 5 °
	6200 mm	2600 mm	2100 mm	6790 mm	1 / 3 °	
	6200 mm	2600 mm	2100 mm	6790 mm		2 ° / 5 °
	6500 mm	2700 mm	2200 mm	7090 mm	0.5 / 2 °	
	6500 mm	2700 mm	2200 mm	7090 mm		2 ° / 5 °
	6800 mm	2800 mm	2300 mm	7390 mm	0.5 / 2 °	
	6800 mm	2800 mm	2300 mm	7390 mm		2 ° / 5 °
	7100 mm	2900 mm	2400 mm	7690 mm	0.5 / 2 °	
	7100 mm	2900 mm	2400 mm	7690 mm		2 ° / 5 °
	7700 mm	3100 mm	2600 mm	8290 mm	0.5 / 1 °	
	7700 mm	3100 mm	2600 mm	8290 mm		2 ° / 5 °
	8420 mm	3340 mm	2840 mm	9010 mm	0.5 / 1 °	
	8420 mm	3340 mm	2840 mm	9010 mm		2 ° / 5 °
9020 mm	3540 mm	3040 mm	9610 mm	0.5 / 1 °		
9020 mm	3540 mm	3040 mm	9610 mm		2 ° / 5 °	
ETV 118n, ETV 120n	Lift (h3)	Retracted mast height (h1)	Free lift (h2)	Extended mast height (h4)	Tilt of mast forwards/backwards	Tilt of fork carriage forwards/backwards
Triplex mast DZ	5000 mm	2300 mm	1700 mm	5590 mm	1 / 5 °	
	5000 mm	2300 mm	1700 mm	5590 mm		2 ° / 5 °
	5300 mm	2400 mm	1800 mm	5890 mm	1 / 5 °	
	5300 mm	2400 mm	1800 mm	5890 mm		2 ° / 5 °
	5900 mm	2600 mm	2000 mm	6490 mm	1 / 3 °	
	5900 mm	2600 mm	2000 mm	6490 mm		2 ° / 5 °
	6200 mm	2700 mm	2100 mm	6790 mm	1 / 3 °	
	6200 mm	2700 mm	2100 mm	6790 mm		2 ° / 5 °
	6500 mm	2800 mm	2200 mm	7090 mm	0.5 / 2 °	
	6500 mm	2800 mm	2200 mm	7090 mm		2 ° / 5 °
	6800 mm	2900 mm	2300 mm	7390 mm	0.5 / 2 °	
	6800 mm	2900 mm	2300 mm	7390 mm		2 ° / 5 °
	7100 mm	3000 mm	2400 mm	7690 mm	0.5 / 2 °	
	7100 mm	3000 mm	2400 mm	7690 mm		2 ° / 5 °
	7700 mm	3200 mm	2600 mm	8290 mm	0.5 / 1 °	
	7700 mm	3200 mm	2600 mm	8290 mm		2 ° / 5 °
	8420 mm	3440 mm	2840 mm	9010 mm	0.5 / 1 °	
	8420 mm	3440 mm	2840 mm	9010 mm		2 ° / 5 °
9020 mm	3640 mm	3040 mm	9610 mm	0.5 / 1 °		
9020 mm	3640 mm	3040 mm	9610 mm		2 ° / 5 °	
ETV 120n	Lift (h3)	Retracted mast height (h1)	Free lift (h2)	Extended mast height (h4)	Tilt of mast forwards/backwards	Tilt of fork carriage forwards/backwards
Triplex mast DZ	9110 mm	3670 mm	3070 mm	9700 mm		2 ° / 5 °
	9620 mm	3840 mm	3240 mm	10210 mm		2 ° / 5 °
	9950 mm	3950 mm	3350 mm	10540 mm		2 ° / 5 °

10220 mm	4040 mm	3440 mm	10810 mm	2° / 5°
10520 mm	4140 mm	3540 mm	11110 mm	2° / 5°
10700 mm	4200 mm	3600 mm	11290 mm	2° / 5°
10880 mm	4260 mm	3660 mm	11470 mm	2° / 5°
11120 mm	4340 mm	3740 mm	11710 mm	2° / 5°
11510 mm	4470 mm	3870 mm	12100 mm	2° / 5°

VDI table

Stand-on: 02/2020

Characteristic	Code	Description	Unit	Jungheinrich			
				ETV 114n	ETV 116n	ETV 118n	ETV 120n
Characteristic	1.1	Manufacturer (abbreviated description)		Jungheinrich			
	1.2	Manufacturer's type designation		ETV 114n	ETV 116n	ETV 118n	ETV 120n
	1.3	Drive		Electric			
	1.4	Operation		Seat			
	1.5	Capacity/load	Q kg	1.400	1.600	1.800	2.000
	1.6	Load centre distance	c mm	600			
	1.8	Load distance, centre of drive axle to fork	x mm	345	395	466	
	1.8.1	Load distance, centre of drive axle to fork, mast extended	mm	205			
	1.9	Wheelbase	y mm	1.410	1.460	1.560	
Weights	2.1.1	Service weight (incl. battery)	kg	2.950	3.070	3.500	3.570
	2.3	Axle load unladen front/rear	kg	1.770 / 1.180	1.842 / 1.228	1.932 / 1.568	1.984 / 1.586
	2.4	Axle load fork forward laden front/rear	kg	522 / 3.828	560 / 4.110	1.009 / 4.291	958 / 4.612
	2.5	Axle load fork back laden front/rear	kg	1.566 / 2.784	1.681 / 2.989	1.765 / 3.535	1.798 / 3.772
Wheels/suspension system	3.1	Tyres		PU			
	3.2	Tyre size, front		Ø 343 x 114			
	3.3	Tyre size, rear		Ø 285 x 100			
	3.5	Wheels, number front/back (x=driven)		1x / 2			
	3.7	Tread width, rear	b ₁₁ mm	1.136			
Basic dimensions	4.2	Retracted mast height (h1)	h ₁ mm	2.300		2.400	
	4.3	Free lift (h2)	h ₂ mm	1.800			
	4.4	Lift (h3)	h ₃ mm	5.300			
	4.5	Extended mast height (h4)	h ₄ mm	6.300		6.400	
	4.7	Height of overhead guard (cab)	h ₆ mm	2.265			
	4.8	Seat height/stand height	h ₇ mm	950			
	4.10	Height of support arms	h ₈ mm	285			
	4.19	Overall length	l ₁ mm	2.346	2.418	2.518	
	4.20	Length including fork shank	l ₂ mm	1.196	1.268		
	4.21	Overall width	b ₁ / b ₂ mm	1.270			
	4.22	Fork dimensions	s/ e/l mm	40 / 120 / 1.150			
	4.23	Fork carriage connection class		2B			
	4.24	Fork carriage width	b ₃ mm	800			
	4.25	Width across forks (dimension 1), WaF	b ₅ mm	335			
	4.25.1	Width across forks (dimension 2)	b ₅ mm	709			
	4.26	Width between support arms/loading areas	b ₄ mm	932			
	4.28	Reach distance	mm	544	594	664	
	4.32	Ground clearance centre of wheelbase	m ₂ mm	80			
	4.34	Aisle width (pallet 1000x1200 sideways)	Ast mm	2.701	2.715	2.766	
	4.34.1	Aisle width (pallet 800x1200 length)	Ast mm	2.757	2.762	2.799	
4.35	Turning radius	W _a mm	1.613	1.663	1.763		
4.37	Length over the support arms	L ₇ mm	1.792	1.842	1.942		
Performance data	5.1	Travel speed laden/unladen	km/h	10 / 10			
	5.2	Lift speed laden/unladen	m/s	0.34 / 0.65	0.32 / 0.60	0.32 / 0.54	
	5.3	Lowering speed laden/unladen	m/s	0.50 / 0.40	0.48 / 0.40	0.45 / 0.38	0.44 / 0.38
	5.4	Reach speed laden/unladen	m/s	0.20 / 0.20			

	5.7	Gradeability laden/unladen	%	7 / 10			
	5.8	Max. gradeability laden/unladen	%	10 / 15			
	5.9	Acceleration time laden/unladen	s	5.1 / 4.8	5.2 / 4.8	5.3 / 4.8	5.4 / 4.8
	5.10	Service brake		electric			
E-motor/Electronics	6.1	Drive motor, performance S2 60 min	kW	6.9			
	6.2	Lift motor, performance with S3	kW	10			
	6.3	Battery according to DIN 43531/35/36		C			
	6.4	Battery voltage / nominal capacity	V / Ah	48 / 420		48 / 620	
	6.5	Battery weight	kg	746		995	
	6.6.1	Energy consumption according to EN cycle	kWh/h	3.8	4.1	4.4	4.7
	6.6.2	CO2 equivalent as per EN 16796	kg/h	2,05	2,22	2,38	2,54
Miscellaneous	8.1	Type of drive control		Mosfet/AC			
	10.1	Working pressure for attachment	bar	150			
	10.2	Oil flow for attachments	l/min	20			
	10.7	Sound level as per EN12053, operator's ear	dB (A)	68			

- In accordance with VDI Guideline 2198 this data sheet provides details of the standard truck only. Non-standard tyres, different masts, optional equipment, etc. may result in different values.

The German production facilities in
Norderstedt, Moosburg and Landsberg
are certified.

ISO 9001
ISO 14001

Jungheinrich fork lift trucks meet
European safety requirements.



 **JUNGHEINRICH**

The logo features a red upward-pointing arrow integrated into the letter 'J' of the word 'JUNGHEINRICH', which is written in a bold, black, sans-serif font.